

Replacement Parts List / Lista De Piezas De Repuesto

All parts may be ordered from your dealer, but not directly from the factory. Be sure that you furnish the following information on all orders. /
 Todas las partes pueden ser pedidas con su concesionario, pero no directamente a la fábrica. Incluya toda la información siguiente con su pedido:

1. Cooler serial number / Número de serie de la unidad
2. Description and part number / Descripción y número de pieza
3. Cooler size / Tamaño de la unidad
4. Date of purchase / Fecha de compra

Failure to supply all of this information will delay your order. / El no proporcionar toda esta información resultará en una demora.

No. N°	Description / Descripción	WCM 28
1.	Top Pan / Tapa De La Caja -----	222901-002
2.	Bottom Pan / Base De La Caja -----	222902-001
3.	Louvered Back / Reja Posterior -----	324102-103
4.	Louvered Side, Right / Reja Lateral, Derecha -----	324102-102
5.	Louvered Side, Left / Reja Lateral, Izquierda -----	324102-202
6.	Aspen Pads, Side / Esponjas De Paja, Lateral -----	110087
7.	Aspen Pads, Back / Esponjas De Paja, Posterior -----	110088
8.	Pad Retainer, Side / Soporte Para La Esponja, Lateral -----	3PW-1
9.	Pad Retainer, Back / Soporte Para La Esponja, Posterior -----	3PW-2
10.	Blower Housing / Caja De La Rueda -----	324102-005
11.	Blower Wheel, Right / Rueda Derecha -----	110748
12.	Blower Wheel, Left / Rueda Izquierda -----	110747
13.	Motor / Motor -----	110441-C*
14.	Motor Mounts / Monturas Del Motor -----	216002-001
15.	Front Panel / Panel De Frente -----	224102-001
16.	Tunnel / Túnel (Cuello De La Unidad) -----	224102-006
17.	Pump Mount / Montura De La Bomba -----	216003-001
18.	Connector, Pump Mount / Unión Para La Montura De La Bomba -----	3PM-1
19.	Pump Retainer / Sujetador De La Bomba -----	110866N
20.	Pump Assembly / Bomba -----	C60-120
21.	Pump Screen / Malla Para La Bomba -----	281001-001
22.	Tube, Water Delivery / Tubo De Agua -----	310716
24.	Water Distributor Assembly / Sistema Del Distribuidor De Agua -----	3D-1
25.	Over Flow Assembly / Montaje De Desagüe -----	3OA-1
26.	Grill Frame / Marco De La Rejilla -----	110834
27.	Directional Louvers / Rejilla Direccional -----	110834-001
28.	Switch Cover / Cubierta Del Interruptor -----	281004-002
29.	Switch / Interruptor -----	110425
30.	Knob, Switch / Perilla Del Interruptor -----	110834-002
31.	Spring Bar / Barra Flexible -----	221001-001
32.	Grommet, Electric Cord / Anillo Del Cable Eléctrico -----	110708
33.	Outer Electrical Cord / Cable Eléctrico Exterior -----	110379
34.	Float Valve / Flotador De Agua -----	FL-C
35.	Window Fill-In Panels / Paneles De Relleno Para La Ventana -----	110604
36.	Retainers, Window Panels / Guarda De Retención Para Los Paneles -----	110599
37.	House Leg Collar / Collar De La Pata -----	3HL-2
38.	House Leg / Pata -----	310811

* See motor specification table. / Vea la tabla de especificaciones del motor.

NOTE: Standard hardware items may be purchased from your local hardware store. /

NOTA: Artículos de uso corriente pueden comprarse en la ferretería de su localidad.

General Specifications / Especificaciones Generales

Model No. Modelo	Weight (lbs.) Peso (libras)		Cabinet Dimensions (in.) Dimensiones De La Caja (pulgadas)			Window Opening Req'd (in.) Abertura Requerida (pulgadas)	
	Dry Seco	Operating Lleno	Height Altura	Width Anchura	Depth Profundidad	Width Anchura	Height Altura
WCM 28	65	105	27	24	17	21 1/4	11

Motor Specifications / Especificaciones Del Motor

Model No. Modelo	Motor Part # Motor - N°	Speed Velocidad	Volts Voltios	Amps Amperios
WCM 28	110441-C	2	115	4.0

Parts Drawing / Dibujo De Piezas

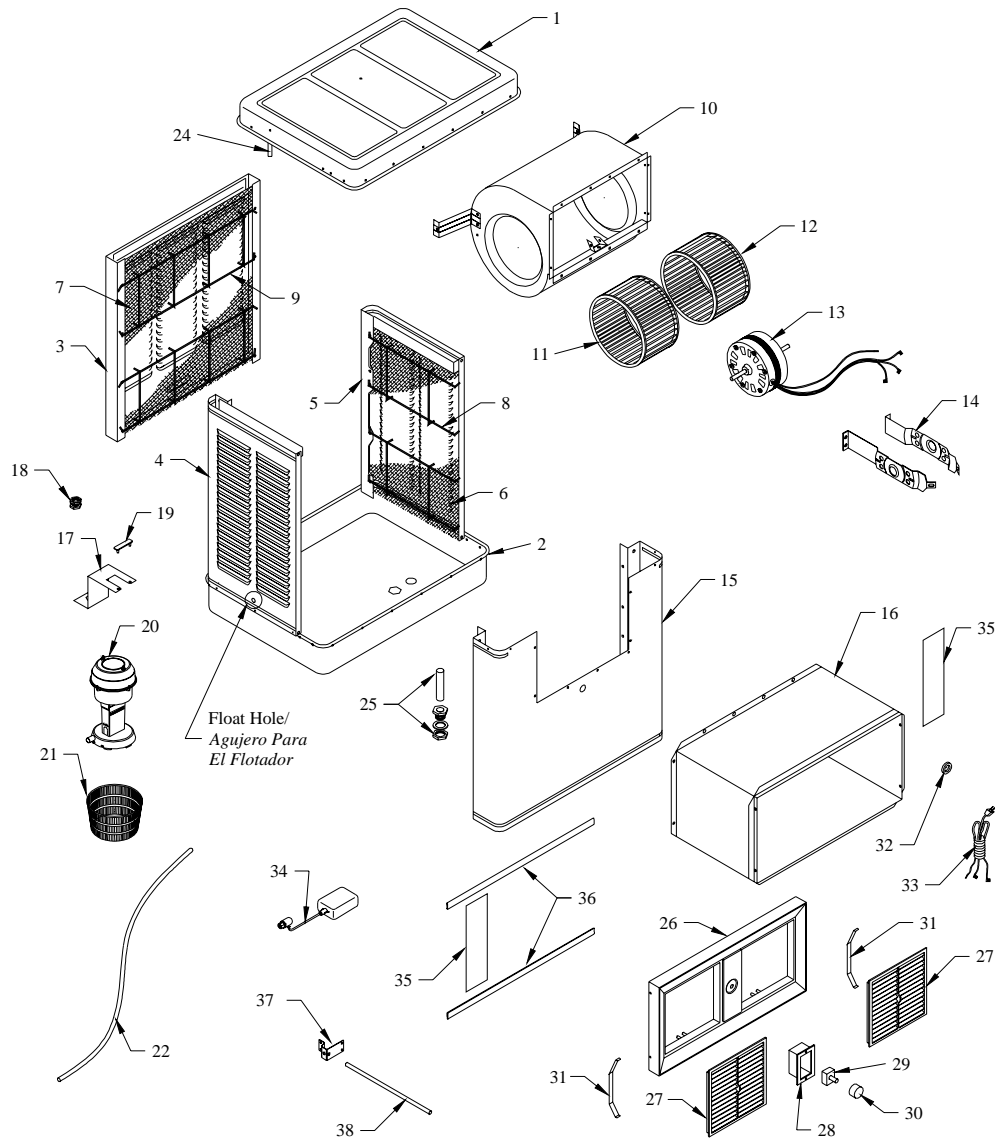

Limited Warranty

This warranty is extended to the original purchaser of an evaporative cooler installed and used under normal conditions. It does not cover damages incurred through accident, neglect, or abuse by the owner. We do not authorize any person or representative to assume for us any other or different liability in connection with this product.

Terms And Conditions Of The Warranty

For Eight Years from date of purchase, we will replace the original base assembly if water leakage should occur due to rust out.

For One Year from date of purchase, we will replace any original component provided by Champion Cooler which fails due to any defect in material or factory workmanship only.

Exclusions From The Warranty

We are not responsible for replacement of cooler pads. These are disposable components and should be replaced periodically. We are not responsible for any incidental or consequential damage resulting from any malfunction.

We are not responsible for any damage received from the use of water softeners, chemicals, descale material, plastic wrap, or if a motor of a higher horsepower than what is shown on the serial plate is used in the unit.

We are not responsible for the cost of service calls to diagnose cause of trouble, or labor charge to repair and/or replace parts.

How To Obtain Service Under This Warranty

Contact the Dealer where you purchased the evaporative cooler. If for any reason you are not satisfied with the response from the dealer, contact the Customer Service Department: Champion Cooler, 5800 Murray Street, Little Rock, Arkansas 72209. 1-800-643-8341. info@championcooler.com

This limited warranty applies to original purchaser only.